

Connector Pinning Layout

WESTERN/FISHER PLUG-N-PLOW CONTROL (JS & HH)

906 Engineering 2019

Western Straight Blade (6-Pin Hard Shell) Fisher Straight Blade (6-Pin Hard Shell)

PIN #	COLOR	FUNCTION
1	BLACK	POS (+)
2	BLUE	RIGHT
3	ORANGE	GROUND
4	BROWN	PUMP SOLENOID
5	RED	RAISE
6	GREEN	FLOAT

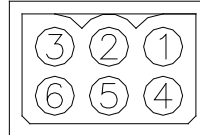

END VIEW
LOOKING AT
CONNECTOR
PIN FACE

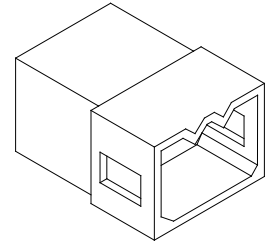

Western Vee Blade (14-Pin Round) Fisher Vee Blade (14-Pin Round)

PIN #	COLOR	FUNCTION
1	WHITE	S6
2	BLUE	S5
3	WHITE/BLACK	S4
4	BLUE/WHITE	S3
5	RED	S2
6	GREEN	S1
7	BROWN	PUMP
8	BLACK	POS +
9	ORANGE	GROUND
10	ORANGE #1	PUMP SOL. GROUND
11	N/A	N/A
12	N/A	N/A
13	N/A	N/A
14	N/A	N/A

END VIEW
LOOKING AT
CONNECTOR
FACE

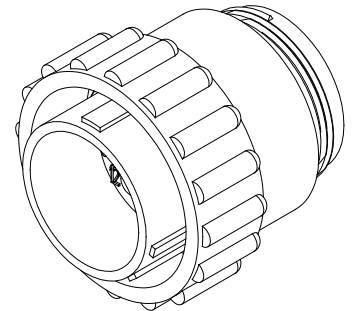
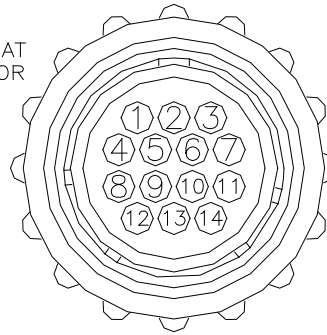

Jumper

Western Straight Blade (4-Pin Multiplex) Western Vee Blade (4-Pin Multiplex) Western Wide Out (4-Pin Multiplex) Fisher Straight Blade (4-Pin Multiplex) Fisher Vee Blade (4-Pin Multiplex) Fisher XLS (4-Pin Multiplex)

PIN #	COLOR	FUNCTION
1	RED	POS (+)
2	GREEN	SIGNAL LINE
3	WHITE	SIGNAL LINE
4	BLACK	NEG (-)

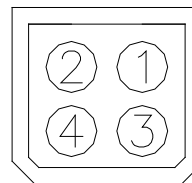

END VIEW
LOOKING AT
CONNECTOR
FACE

Note: A lot of older plows with mechanical switches require no ground to operate. All of our Plug-N-Plow controls do require a ground to operate.

Hint: If your control is not functioning properly, check to make sure it is properly grounded.

Connector Pinning Layout

MEYERS/DIAMOND PLUG-N-PLOW CONTROL (JS & HH)

906 Engineering 2019

Meyers/Diamond Straight Blade (6-Pin)

PIN #	COLOR	FUNCTION
1	RED	RAISE
2	BLUE	RIGHT
3	GREEN	FLOAT
4	BROWN	PUMP SOLENOID
5	BLACK	POS (+)
6	ORANGE	GROUND

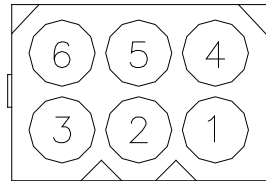

END VIEW
LOOKING AT
CONNECTOR
PIN FACE

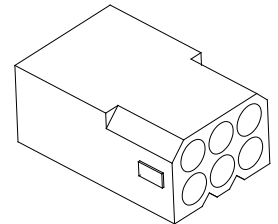

Meyers Vee Blade (9-Pin) V-66 Quick Lift

PIN #	COLOR	FUNCTION
1	GREEN	FLOAT
	GREEN	FLOAT
2	ORANGE	GROUND
3	BLACK	POS (+)
4	BROWN	PUMP
	BROWN	PUMP
5	RED	RAISE
6	BLUE	L EXTEND
7	BLUE/WHITE	L RETRACT
8	WHITE	R EXTEND
9	WHITE/BLACK	R RETRACT

END VIEW
LOOKING AT
PIN FACE

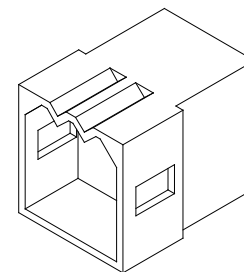
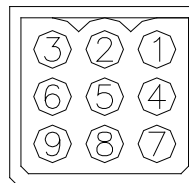

Meyers Straight Blade (12-Pin) Meyers Vee Blade (12-Pin) V-68 & V-70 Meyers Vee Blade (12-Pin) V-71

PIN #	PRE. COLOR	SB	V-68 & 70	V-71
1	GREEN	B	B	S1
	GREEN			
2	BLUE	C	C	S3
3	RED	A	A	S2
4	BROWN	PUMP	PUMP	PUMP
	BROWN			
5	BLACK	POS (+)	POS (+)	POS (+)
	ORANGE #2			
6	ORANGE	GROUND	GROUND	GROUND
7	ORANGE #2	PLOW LIGHT	PLOW LIGHT	PLOW LIGHT
8	BLUE/WHITE	N/A	D	S5
9	WHITE/BLACK	N/A	E (Dismount)	S7
10	N/A	REV - INPUT	REV - INPUT	REV - INPUT
11	N/A	N/A	N/A	
12	WHITE	N/A	-	S6

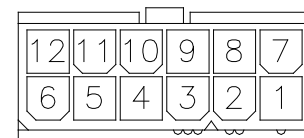

END VIEW
LOOKING AT
CONNECTOR
PIN FACE

Jumper

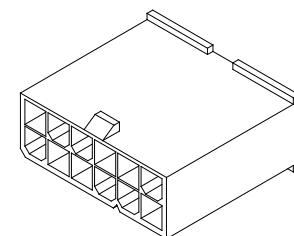

Note: A lot of older plows with mechanical switches require no ground to operate. All of our Plug-N-Plow controls do require a ground to operate.

Hint: If your control is not functioning properly, check to make sure it is properly grounded.

Connector Pinning Layout

BLIZZARD PLUG-N-PLOW CONTROL (JS & HH)

Blizzard Straight Blade (12-Pin)

906 Engineering 2019

PIN #	COLOR	FUNCTION
1	N/A	N/A
2	N/A	N/A
3	BLACK #1	SWITCH 12 VOLT +
4	GREEN GREEN	FLOAT
5	N/A	N/A
6	N/A	N/A
7	ORANGE	GROUND
8	RED	LIFT
9	BROWN BROWN	PUMP SOLENOID
10	WHITE/BLACK BLUE/WHITE	12 (+) DC FUSED
11	BLUE	RIGHT ANGLE
12	WHITE	LEFT ANGLE

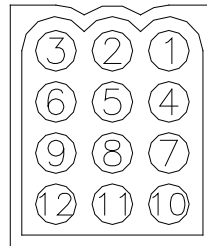

END VIEW
LOOKING AT
CONNECTOR
FACE

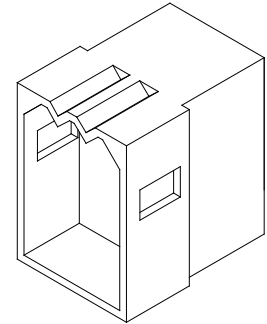

Blizzard 810 Power Plow (12-Pin)

PIN #	COLOR	FUNCTION
1	RED/WHITE	RIGHT EXTEND
2	RED/BLACK	RIGHT RETRACT
3	RED #1	SWITCH 12 VOLT +
4	ORANGE ORANGE	FLOAT
5	BLUE/WHITE	LEFT EXTEND
6	BLUE/BLACK	LEFT RETRACT
7	BLACK	GROUND
8	WHITE	LIFT
9	BROWN BROWN	PUMP SOLENOID
10	ORANGE/BL #1 ORANGE/BL #2	12 (+) DC FUSED
11	GREEN	RIGHT ANGLE
12	BLUE	LEFT ANGLE

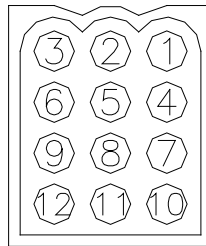

END VIEW
LOOKING AT
CONNECTOR
FACE

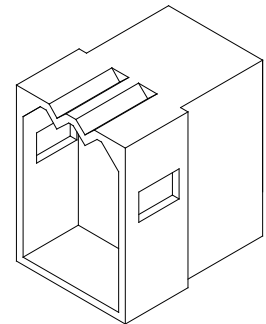

Blizzard Straight Blade (4-Pin Multiplex)

Blizzard Speedwing SB w/ Wings (4-Pin Multiplex)

Blizzard Power Plow (4-Pin Multiplex)

PIN #	COLOR	FUNCTION
1	RED	POS (+)
2	GREEN	SIGNAL LINE
3	WHITE	SIGNAL LINE
4	BLACK	NEG (-)

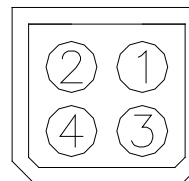

END VIEW
LOOKING AT
CONNECTOR
FACE

Note: A lot of older plows with mechanical switches require no ground to operate. All of our Plug-N-Plow controls do require a ground to operate.

Hint: If your control is not functioning properly, check to make sure it is properly grounded.

Connector Pinning Layout

HINIKER PLUG-N-PLOW CONTROL (JS & HH)

Hiniker Straight Blade

906 Engineering 2019

PIN #	COLOR	FUNCTION
1	BROWN	PUMP SOL.
	BROWN	PUMP SOL.
2	GREEN	FLOAT
	GREEN	FLOAT
3	BLACK	POS (+)
4	ORANGE	GROUND
	ORANGE #2	GROUND
5	BLUE	LEFT
6	WHITE	RIGHT
7	ORANGE #2	LIGHTS

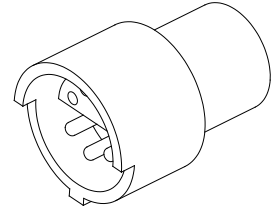
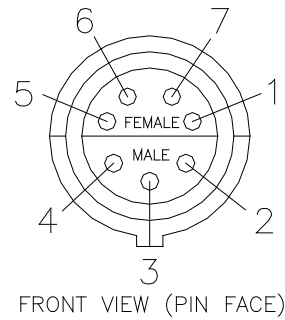

Hiniker Vee Blade with Single Acting Cylinders

Hiniker C-Plow

Hiniker Vee Blade with DBL Acting Cylinders

PIN #	COLOR	C-PLOW	VEE
1	BROWN	PUMP SOL.	PUMP SOL.
	BROWN	PUMP SOL.	PUMP SOL.
2	GREEN	FLOAT	FLOAT
	GREEN	FLOAT	FLOAT
3	BLACK	POS (+)	POS (+)
4	ORANGE	GROUND	GROUND
	ORANGE #2	GROUND	GROUND
5	BLUE	LEFT	LEFT-RETRACT
6	WHITE	RIGHT	RIGHT-RETRACT
7	ORANGE #2	LIGHTS	LIGHTS

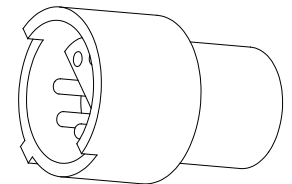
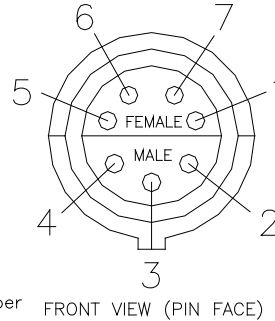

PIN #	COLOR	C-PLOW	VEE
1	WHITE/BLACK	PULL	L-EXT
2	BLUE/WHITE	PUSH	R-EXT
3	RED	RAISE	RAISE

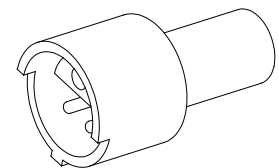
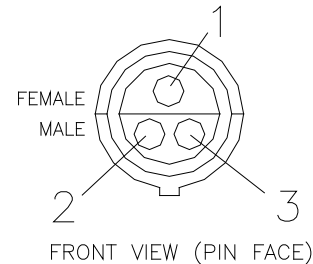

Note: A lot of older plows with mechanical switches require no ground to operate. All of our Plug-N-Plow controls do require a ground to operate.

Hint: If your control is not functioning properly, check to make sure it is properly grounded.

Connector Pinning Layout

BOSS PLUG-N-PLOW CONTROL (JS & HH)

Boss Straight Blade
Boss Vee Blade

906 Engineering 2019

PIN #	COLOR	FUNCTION
1	BLACK	12v +
2	GREEN	FLOAT
3	RED	UP
4	WHITE	RIGHT OUT (SB-L)
5	WHITE/BLACK	RIGHT IN (SB-R)
6	BLUE	LEFT OUT (SB-R)
7	BLUE/WHITE	LEFT IN (SB-L)
8	BROWN	PUMP SOL
9	ORANGE	GROUND

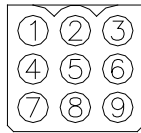

END VIEW
LOOKING AT
CONNECTOR
PIN FACE

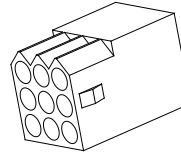

SNOWDOGG PLUG-N-PLOW CONTROL (JS & HH)

SnowDogg Straight Blade
SnowDogg Vee Blade
SnowDogg Wing Blade

906 Engineering 2019

PIN #	PRE. COLOR	FUNCTION	VEE	WING	SB
1	BROWN	PUMP SOLENOID	PUMP	PUMP	PUMP
	BROWN/WHITE	PUMP SOLENOID			
2	BLUE	SOL. A	RAISE	RAISE	LOWER
	GREEN	SOL. B			
3	WHITE	SOL. B	R-OUT/RIGHT	R-OUT/LEFT	RAISE
	ORANGE	SOL. C			
4	ORANGE	SOL. C	L-OUT/LEFT	RIGHT	RIGHT
	ORANGE	SOL. C			
5	RED #1	POS (+)	POS (+)	POS (+)	POS (+)
6	ORANGE/WHITE	SOL. D	R&L-OUT/SCOOP	L&R-IN	LOWER
7	RED/BLACK	SOL. E	L-IN/VEE	L-IN/L-OUT	RAISE
8	BLUE/BLACK	SOL. F	R-IN/VEE	R-IN/R-OUT	RIGHT
9	BLACK	GROUND	GROUND	GROUND	GROUND
10	RED/WHITE	POS (+)	POS (+)	POS (+)	POS (+)
11	BLUE/WHITE	SOL. G	LOWER	LOWER	N/A
12	ORANGE/BLACK	SOL. D	SEE NOTE	SEE NOTE	LOWER

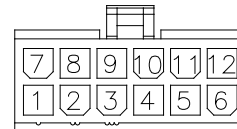

END VIEW
PIN FACE

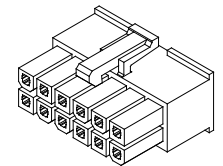

CURTIS PLUG-N-PLOW CONTROL (JS & HH)

Curtis Straight Blade
Curtis Vee Blade

906 Engineering 2019

PIN #	COLOR	VB FUNCTION	SB FUNCTION
1	BLACK #1	12v +	12v +
2	BLUE	LEFT EXT.	LEFT
3	WHITE	RIGHT EXT.	RIGHT
4	RED	RAISE	RAISE
5	GREEN	FLOAT	FLOAT
	GREEN	FLOAT	FLOAT
6	BROWN	PUMP SOLENOID	PUMP SOLENOID
	BROWN	PUMP SOLENOID	PUMP SOLENOID
7	ORANGE	GROUND -	GROUND -
8	BLUE/WHITE	LEFT RETRACT	N/A
9	WHITE/BLACK	RIGHT RETRACT	N/A

END VIEW
LOOKING AT
PIN FACE

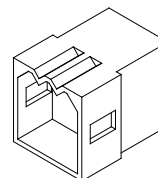
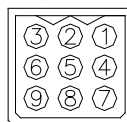

Note: A lot of older plows with mechanical switches require no ground to operate. All of our Plug-N-Plow controls do require a ground to operate.

Hint: If your control is not functioning properly, check to make sure it is properly grounded.

Connector Pinning Layout

SNOWEX PLUG-N-PLOW CONTROL (JS & HH)

SnowEx Straight Blade (4-Pin Multiplex)
 SnowEx Vee Blade (4-Pin Multiplex)
 SnowEx Wing Blade (4-Pin Multiplex)

906 Engineering 2019

PIN #	COLOR	FUNCTION
1	RED	POS (+)
2	GREEN	SIGNAL LINE
3	WHITE	SIGNAL LINE
4	BLACK	NEG (-)

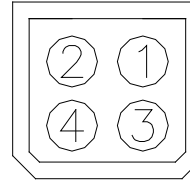

END VIEW
LOOKING AT
CONNECTOR
FACE

AIRFLO PLUG-N-PLOW CONTROL (JS & HH)

Airflo Straight Blade
 Airflo Vee Blade

906 Engineering 2019

PIN #	PRE. COLOR	SB FUNCTION
1	BLACK #1	POS (+)
2	WHITE	RAISE
	GREEN	FLOAT
3	GREEN	FLOAT
	BROWN	PUMP
4	BROWN	PUMP
	BROWN	PUMP
5	RED	RIGHT
6	BLUE	LEFT
7	WHITE/BLACK	AUX-1
8	N/A	N/A
9	N/A	N/A
10	BLUE/WHITE	AUX-2
11	N/A	N/A
12	ORANGE	GROUND

PIN #	PRE. COLOR	VB FUNCTION
1	RED #1	POS (+)
2	WHITE	RAISE
	ORANGE	FLOAT
3	ORANGE	FLOAT
	BROWN	PUMP SOLENOID
4	BROWN	PUMP SOLENOID
	BROWN	PUMP SOLENOID
5	GREEN	RIGHT
6	BLUE	LEFT
7	RED/WHITE	RIGHT WING OUT
8	RED/BLACK	RIGHT WING IN
9	ORANGE/BK	N/A
10	ORANGE/BK	
	ORANGE/BK	
10	BLUE/WHITE	LEFT WING OUT
11	BLUE/BLACK	LEFT WING IN
12	BLACK	GROUND

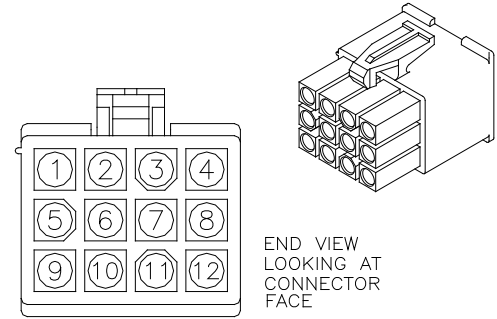

END VIEW
LOOKING AT
CONNECTOR
FACE

UNIVERSAL PLUG-N-PLOW CONTROL (JS & HH)

Note: Universal Straight Blade has the same connector & plugging as the Airflo control

Note: A lot of older plows with mechanical switches require no ground to operate. All of our Plug-N-Plow controls do require a ground to operate.

Hint: If your control is not functioning properly, check to make sure it is properly grounded.